

COMPARTMENT DIMENSIONS		
COMPT.	CLEAR DOOR OPENING (W x H):	COMPARTMENT INTERIOR (W x H x LD/UD):
L1	24-1/2"W x 27-3/4"H	27"W x 38"H x 26"D
L2	19-1/2"W x 27-3/4"H	22"W x 38"H x 26"D
R1	52-1/2"W x 27-3/4"H	55"W x 38"H x 26"D
R2	19-1/2"W x 27-3/4"H	22"W x 38"H x 26"D

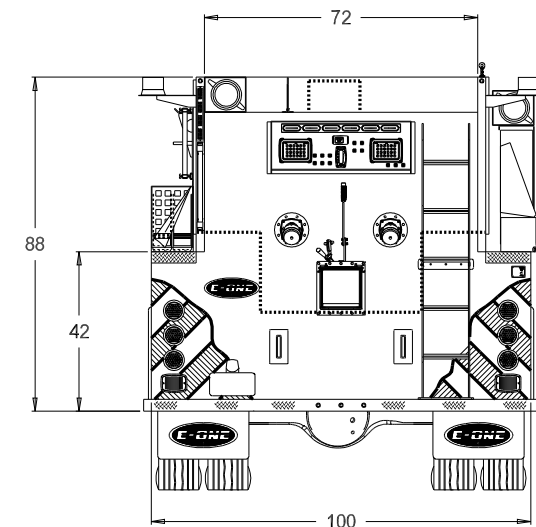
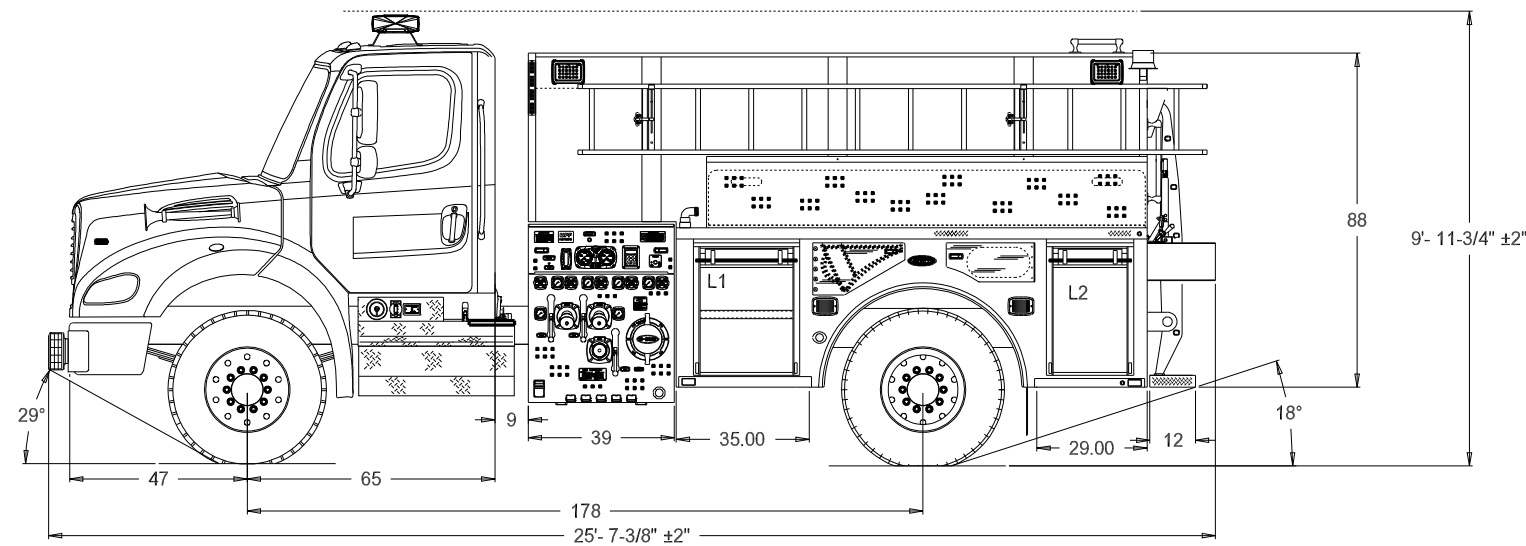

THIS DRAWING IS FOR REFERENCE PURPOSES. ALL DIMENSIONS ARE SUBJECT TO MINOR VARIATIONS DUE TO MANUFACTURING PROCESSES.

This print is the property of E-ONE Inc. and is loaned to you subject to return on demand, unless otherwise agreed to in writing by E-ONE Inc. Its contents are confidential and must not be copied or submitted to third parties for use or examination.

REV.	REVISION NOTE / CO#:	DATE:	DRAWN BY:
A	INITIAL DRAWING	030320	JDP
B	UPDATED PER CRs QUOTE REV LEVEL 10	040720	JDP
C	UPDATED PER CRs QUOTE REV LEVEL 12	041720	JDP
D	UPDATED PER CRs QUOTE REV LEVEL 19	061820	JDP

Tolerance:	Lin: ±.50" Ang: ±50 °
Dealer:	FIRE CONNECTIONS
Generator:	GENERATOR:
Misc:	Misc:

Units:	Inches [mm Imports Only]
Water Tank Capacity:	2000 GALLON
Misc:	Misc:



SPRUCE PINE FIRE & RESCUE

QUOTE NO. 102328
 SO NO. 144141
 2 DOOR FREIGHTLINER M2 112 CAB
 2000 GALLON WETSIDE TANKER

DEALER APPROVAL _____

DATE _____

AS IS

CUSTOMER APPROVAL _____

DATE _____

WITH REVISIONS